

Indoor/Outdoor high-speed IP PTZ camera system with IOP and multi-protocol capabilities



FEATURES

- SONY cameras
- High strength aluminum alloy, high temperature resistance, anti-corruption
- Integrated with INFINOVA and PELCO-P/D, self-adaptive protocol
- Set address and baud rate via software
- 254 selectable addresses
- Up to 255 presets with labels
- 6 programmable tours
- 4 programmable patterns
- 4 Auto-Pan
- 1 Auto-Scan
- Automatically return to home position
- 1 privacy area function
- 16 programmable zones with 16 characters each
- 18X, 26X and 36X optic zoom available
- Window wiper, built-in heater, window defroster/defogger included
- Network video transmission and network control function
- MPEG-4 coding method, real time transmission video image
- View and control cameras via Web Server or V2216 software by multiple users
- Password protection
- Manually IP address set up
- Support Dynamic IP Frame Ratio, dynamic quality and compression rate adjustment (via network)
- Snapshot function
- Controllable Digital Focus (Digital Zoom)
- Remote Software Updating through the network
- Operational in 90 mph wind conditions; withstanding wind velocity of up to 130 mph
- Multi-mounting methods (indoor or outdoor)

DIMENSIONS (Unit: inch, in the parentheses is mm)

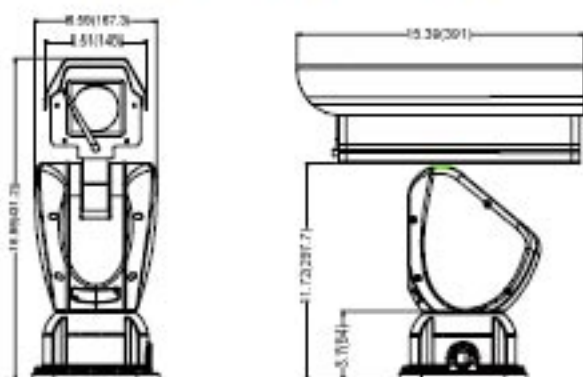

SPECIFICATIONS

General

Decoder:	INFINOVA, PELCO-P/D
Maximum Presets:	255
Tour:	6
Pattern:	4
AutoPan:	4
AutoScan:	1

Video

Video Coding:	MPEG-4
Resolution Mode:	D1/ 2CIF/ CIF/ QCIF
Image Resolution:	
NTSC:	720x480, 704x240, 352x240, 176x120
PAL:	720x576, 704 x 288, 352x288, 176x144
Frame Rate (maximum):	
NTSC:	720 x 480, 30 fps / 720 x 240, 60 fps (Interlace scanning)
PAL:	720 x 576, 25 fps / 720 x 288, 50 fps (Interlace scanning)
Ethernet Port:	10/100M Base-T self-adaptive, RJ45
Ethernet Protocol:	TCP/IP, DHCP, HTTP, SNMP, ICMP

Preset Speed

Pan:	Maximum 100°/sec.
Tilt:	Maximum 30°/sec.
Pan Rotation Angle:	360°
Tilt Rotation Angle:	+40° ~ -90°
Construction:	Die-cast, extruded and sheet aluminum; stainless steel hardware
Weight:	21 lbs. (9.5 kg)
Load:	33 lbs. (15 kg)
Environmental Rating:	IP66
Mounting Method:	Desktop, wall, pole side, corner, pole top

Electrical

Input Voltage:	24 VDC / 24 VAC / 120 VAC / 230 VAC
Power:	< 85W
Heater:	Thermostatically controlled

Mechanical

Variable Pan/Tilt Speed

Pan:	0.1°~50°/sec.
Tilt:	0.1°~25°/sec.

Environmental

Environment Air Pressure:	≤1.5 Mpa
Operation:	-22° F ~ 140° F (-30° C ~ 60° C)
Humidity:	≤95% RH (non-condensing)

Auto Temperature Control

Heater:	Turns on at 46° F ± 9° F (8° C ± 5° C)
	Turns off at 68° F ± 9° F (20° C ± 5° C)